



October | 2025

NZ

# 3Dx™ 7t Slim Edge Lifting Anchor

Compliance Document

Reid™ 3Dx™ 7t Slim  
Edge Lifting Anchors  
comply with NZ Good  
Practice Guidelines:  
Safe work with precast  
concrete (2018)



reids.co.nz | 0800 88 22 12

# 3Dx™ 7t Slim Edge Lifting Anchor



**3Dx™ 7t Slim Edge Lifting Anchors do not require a shear bar or additional reinforcement to achieve full capacity, removing cost and risk from every panel.**

Designed for heavily congested, double-layer panels in the New Zealand market, to perform in New Zealand concrete, reinforced with New Zealand reinforcing bar. **This product meets the building code requirements for durability B2 Durability, B2.3.1.**



**Figure 1:**  
3Dx™ 7t Slim Edge Lifting Anchors

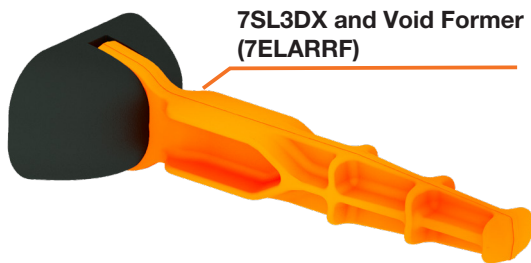

7SL3DX



## Edge Lifting Anchor Features

- Forged I-Beam design removes the need for shear bars.
- Shares the same void as the twin-leg 7t anchor (7ELARRF).
- Backwards compatible with 7ELALE clutches.
- Hot-dip galvanised to AS/NZS 4680.
- AnchorShield™ epoxy coated, to mitigate galvanic reactions in precast panel production and prevent poor quality finishes.
- Orange colour for easy visual QA checks.
- Simple & easy to use, no extra reinforcement or difficult install methodology.
- Tested to NZ conditions using NZ materials.



# Compliance Details

**Table I: NZ GPG 2018 Compliance Details**

Clause	Requirement	Compliant
6.6	The minimum FOS for general lifting needs to be 3.0 and for repetitive lifting needs to be 5.0.	
6.6	The design of the lifting anchor shall include the ductile behavior and robustness of the anchor.	
10.11	Lifting clutches are to be made in accordance with a valid international standard or technical reference.	
10.11	Every item of lifting equipment should be clearly and permanently marked with its WLL. A unique numbering system to clearly identify individual items should be used.	
10.11	Lifting clutches are to be tested for loads in all directions and initially tested by the supplier to a factor of safety of 2.0	
10.11	Inspected at least every 12 months by a competent person, and a record kept of those inspections.	

## Edge Lifting Anchor Compliance

- Every individual item of lifting equipment should be clearly marked with its working load limit (WLL), the manufacturer’s identifier, and a unique numbering system.
- Lifting anchors that are used for lifting and handling during all stages of manufacture, delivery and installation should be designed to a minimum safety factor of 3.0.
- As with lifting clutches, lifting anchors should be manufactured and tested in accordance with a valid international standard or technical reference.
- Development, production, testing, inspection and application of lifting anchors and lifting anchor systems should meet acceptably high and consistent standards to ensure that they are fit for purpose.



# Specifications & Product Markings



The 7SL3DX anchor has a 7t WLL and is forged, hot-dip galvanised and then AnchorShield™ epoxy coated. Its patented I-beam & toothed design allows the anchor to be more compact than the previous hairpin 7HPAWFP. The 7SL3DX is specifically designed for use in low and early strength concrete, allowing the precaster the shortest possible cycle times.

**Table 2: Part Number & Pack Quantities**

Part No.	WLL	Length (mm)	Pack Qty
7SL3DX	7t	283	200/crate

**Figure 2: Reid™ 7SL3DX Anchor Markings**

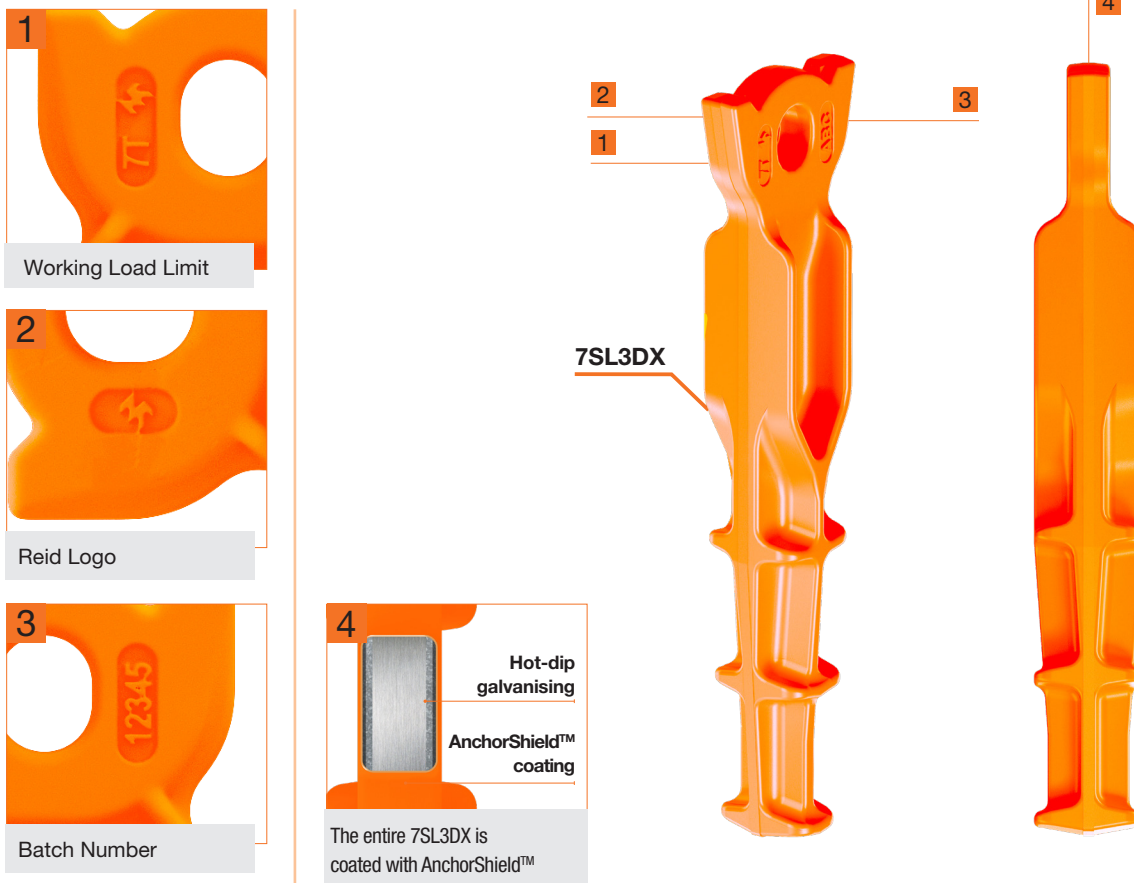

# 3Dx™ 7t Slim Edge Lifting Anchor

## Product Specifications (mm)

Figure 3: 7SL3DX - 3Dx™ 7t Slim Edge Lifting Anchor Dimensions

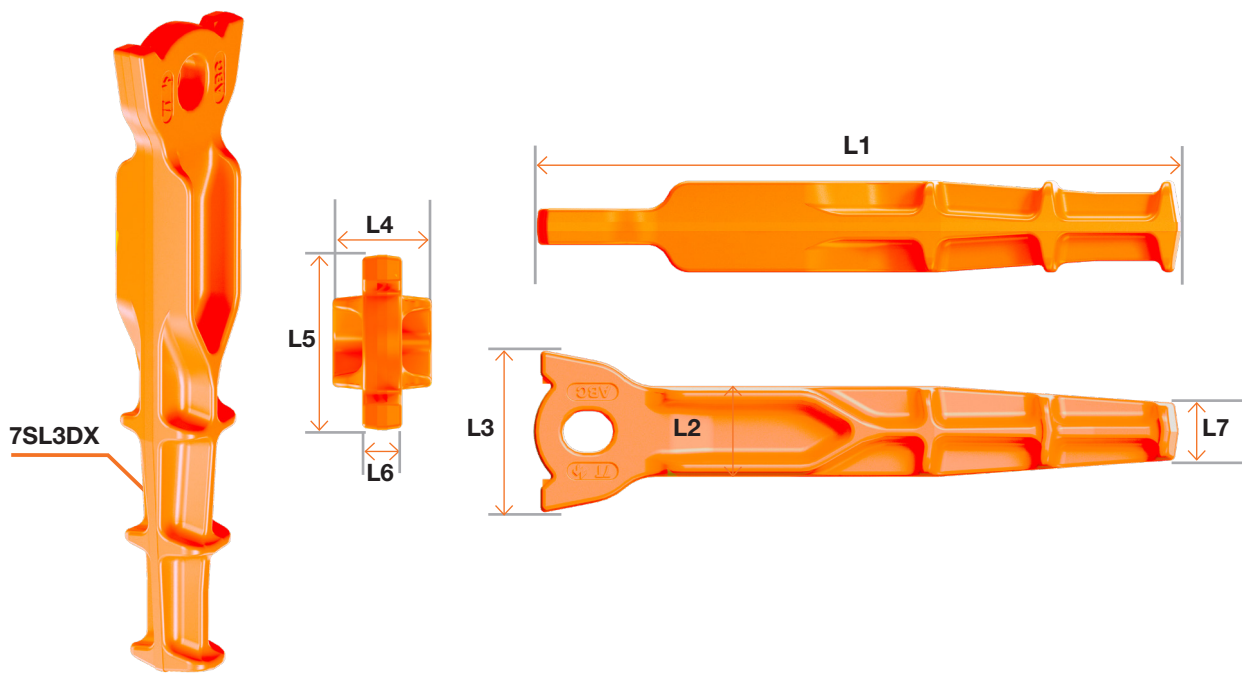



Table 3: 7SL3DX - 3Dx™ 7t Slim Edge Lifting Anchor Dimensions

Load Group (t)	Nominal Dimensions (mm)						
	L1	L2	L3	L4	L5	L6	L7
7.0 	283	40	72	40	72	16	25

**Note:** Reid™ reserve the right to change the above specifications.

The above Nominal Dimensions are based on manufacture in 2025.

# 3Dx™ 7t Slim Edge Lifting Anchor

## Product Specifications (mm)

Figure 4: Minimum edge and spacing distances

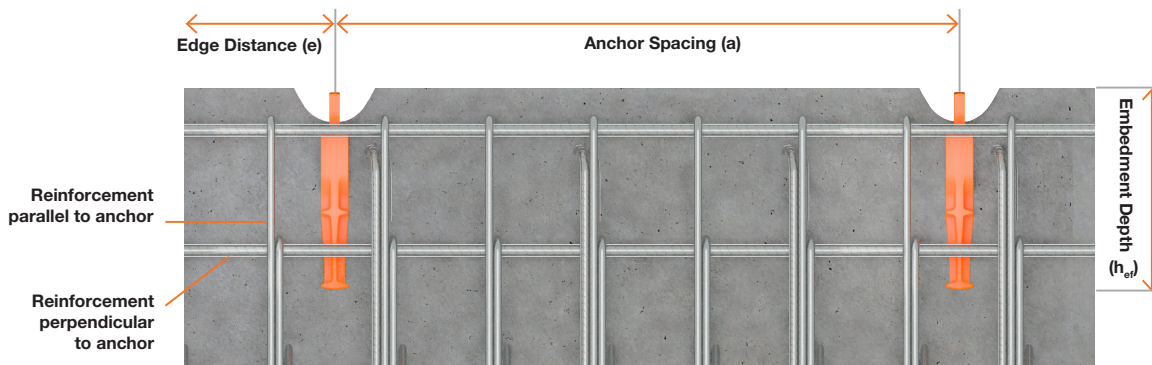

Table 4a: Minimum edge and spacing distances required to achieve performances in Table 5.

Minimum Edge and Spacing Limits			
Minimum Panel Thickness (mm)	Edge Distance e, (mm)	Anchor Spacing a, (mm)	Embedment Depth $h_{ef}$ (mm)
7SL3DX	450	900	287

Note: For guidance on reduced edge distance and anchor spacing, please refer to capacity reduction factors in Table 4b.

Table 4b: Anchor Spacing and Edge Distance Capacity Reduction Factors to be applied on performance values in Table 5.

Substrate Thickness	Tensile Capacity Reduction Factor - $\phi_n$		Shear Capacity Reduction Factor - $\phi_v$	
	7SL3DX		7SL3DX	
	a (mm)	e (mm)	a (mm)	e (mm)
	500	250	500	250
150-200	0.50		1.0	

Note: Apply Anchor Spacing and Edge Distance Capacity Reduction Factors as follows,

- Tensile Capacity Reduced = Tensile Capacity (Table 5) x  $\phi_n$
- Shear Capacity Reduced = Shear Capacity (Table 5) x  $\phi_v$

Note: Reid™ reserve the right to change the above specifications.

# 3Dx™ 7t Slim Edge Lifting Anchor

## Performance Data

**Table 5: 7SL3DX Performance Data (Tonne per anchor)**

Panel Thickness (mm)	Max. WLL (Tonne)	15 MPa		20 MPa		25 MPa		30 MPa		35 MPa		40 MPa		Min. Panel Reinforcement**
		Tension WLL	Shear* Stripping	Tension WLL	Shear* Stripping	Tension WLL	Shear* Stripping	Tension WLL	Shear* Stripping	Tension WLL	Shear* Stripping	Tension WLL	Shear* Stripping	
150	7	2.5	1.7	2.8	1.8	3.1	2.0	3.5	2.1	3.8	2.2	4.0	2.3	Minimal Reinforcement***
		4.9	2.0	5.6	2.2	6.3	2.3	7.0	2.5	7.0	2.6	7.0	2.8	HD12@300 CTRS Double
175		2.9	2.0	3.4	2.1	3.8	2.3	4.0	2.4	4.2	2.5	4.4	2.6	Minimal Reinforcement***
		5.8	2.4	6.2	2.7	7.0	3.1	7.0	3.1	7.0	3.1	7.0	3.3	HD12@300 CTRS Double
200		3.1	2.3	3.5	2.4	3.9	2.6	4.2	2.7	4.5	2.9	4.8	3.2	Minimal Reinforcement***
		6.6	2.8	6.9	3.1	7.0	3.5	7.0	3.7	7.0	4.0	7.0	4.3	HD20@300 CTRS Double

**Note:** Data is based on concrete panel with vertical reinforcement detail as noted in table and satisfies the minimum requirement stipulated in clause 11.4.4.2 of NZS 3101:2006 (A3) for 500E grade. If reinforcement detail is less, contact your local Reid™ representative for advice. The performance data in this table is based on the minimum edge distance and anchor spacing detailed in Table 4 of this document.

\* Shear data is for out-of-plane application and based on avoiding cracking around lifter during the stripping process. This process assumes one edge of the panel is still on the bed whilst tilting it up until vertical. If the panel were to be flat lifted after stripping or tilted up in mid-air rotation, all shear capacities need to be multiplied by a capacity reduction factor of  $\phi = 0.37$  for WLL - refer to diagrams below for detail.

\*\* Data is based on concrete panel with vertical reinforcement detail as noted in above table.

\*\*\* Shear testing was conducted in unreinforced concrete and capacities derived accordingly. It is strongly advised that the minimum panel reinforcement complies with NZS 3101:2006 (A3).

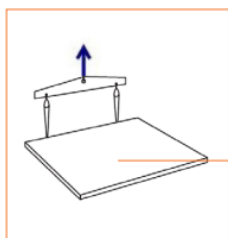

Stripping utilising edge lifters

Stripping Capacity

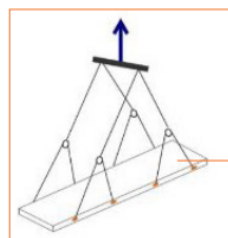

Flat lift utilising edge lifters

$WLL(\text{Shear}) = \phi \times \text{Shear Stripping Capacity}$

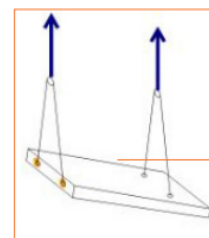

Mid-air rotation utilising edge lifters



# Important Lifting Systems Compatibility Information



When lifting or tilting precast concrete panels, ensuring the correct combination of components is not just recommended – it's essential. Reid™ lifting systems are engineered as a complete solution, designed for maximum safety, compliance, and performance when used as intended: with fully compatible Reid™ components. This guide outlines the critical compatibility requirements, reinforcing our commitment to safe and compliant lifting practices across New Zealand.



## SAFETY

Safety is our highest priority when it comes to lifting or tilting concrete panels and elements.



## OPTIMUM PERFORMANCE

Reid™ lifting products are engineered as a complete system to achieve the stated working load limits within defined safety margins. This performance can only be assured when all components used are genuine Reid products.



## COMPLIANCE

Reid™ Clutches are specifically designed, tested, and tagged to comply with the Safe Work with Precast Concrete: Handling, Transportation and Erection of Precast Concrete Elements – Good Practice Guidelines (October 2018). Systems compliance is exclusively achieved and maintained when compatible Reid lifting components are used.



## NO MIX & MATCH

Reid™ does not approve the use of non-Reid lifting products with Reid components. Mixing products from other suppliers renders the system non-compliant and may compromise safety and performance.



## SUPPORT

For full guidance on compatible products, refer to our Precast Solutions Product Guide covering all Reid™ lifting components available in the New Zealand market. All Reid™ products are stamped with the Reid logo for easy identification. For further support or technical queries, visit [reids.co.nz](http://reids.co.nz) or contact your Reid Sales Representative.



All Reid™ products have the Reid™ logo or icon stamped for ease of identification and compatibility.

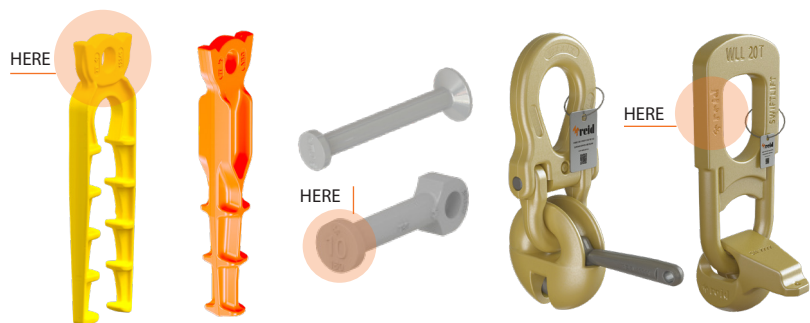













# Systems Compatibility

Edge Lifting Systems

The 3DX components as outlined below are compatible. Adding the 7SL3DX SLIM to an established twin-leg 3DX7N in-yard lifting infrastructure does NOT require any investment for different lifting clutches or void formers.

**Table 6: 7 Tonne Edge Lifting Systems**

Anchor			Lifting Clutch		Void Former
					Isometric View: 
7ELAWF	3DX7N	7SL3DX			Top View: 
			7ELALE	3DX7NLC	7ELARRF







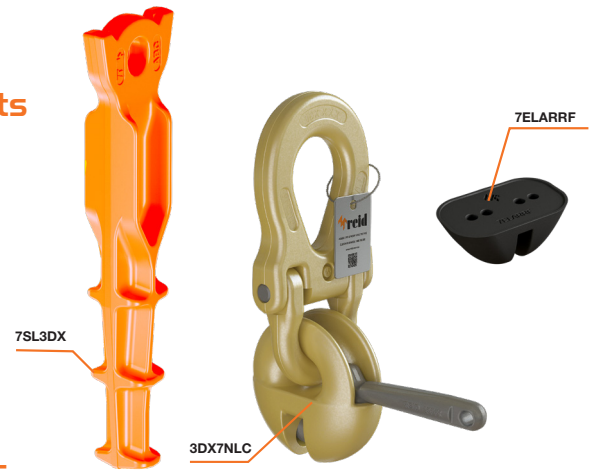

Reid™ Lifting Systems comply with NZ Good Practice Guide: Safe Work with Precast Concrete (2018). Please refer to the relevant Compliance Document for further information.

**Figure 5:**  
3Dx™ 7t Slim Edge Lifting System Components



**Table 7:**  
3Dx™ 7t Slim Edge Lifting System Compliance

Part	Part No.	NZ GPG:2018 Compliant
Anchor	 7SL3DX	
Lifting Clutch	 7ELALE  3DX7NLC	
Void Former	 7ELARRF	

# Installation

## Support details

**Figure 6: Double Layer Reinforcing Placement Detail**



Designed for heavily congested,  
double-layer reinforced panels.

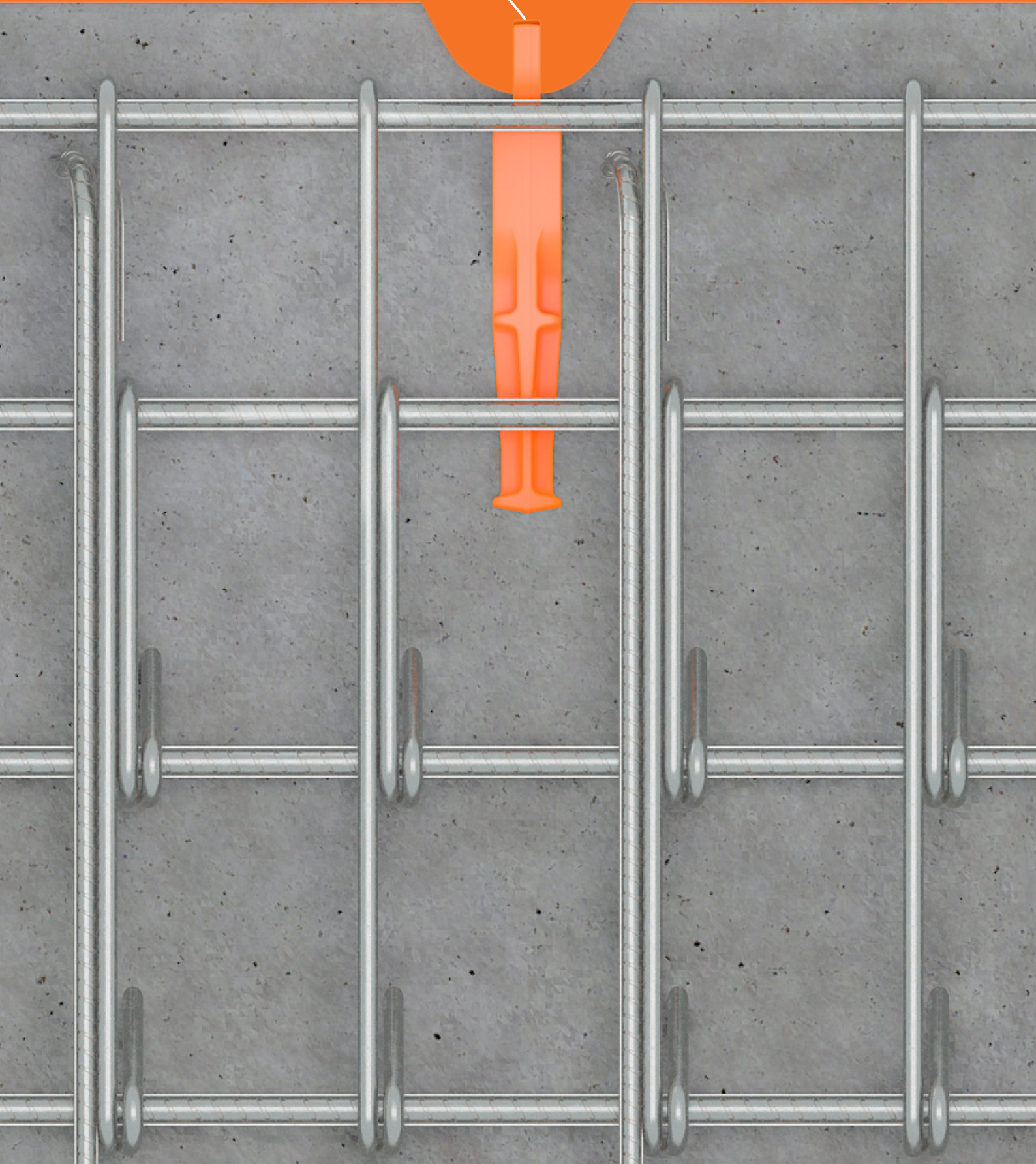



## Customer Service

### Reid™ New Zealand

Tel: 0800 88 22 12

Email: [sales@ramsetreid.co.nz](mailto:sales@ramsetreid.co.nz)

Web: [www.reids.co.nz](http://www.reids.co.nz)

#### Reid™

AUS: 1 Ramset Drive, Chirnside Park, Victoria, Australia, 3116

NZ: 23-29 Poland Road, Glenfield, Auckland 0632

Information in this document is correct at the time of printing. Readers should contact Reid™ or consult Reid™ detailed technical information to ensure product is suitable for intended use prior to purchase.

ITW Australia Pty Ltd ABN 63 004 235 063 trading as Reid™ © copyright 2025.

™ Trademarks of Illinois Tool Works Inc used under license by Reid™

**Important Disclaimer:** Any engineering information or advice ("Information") provided by Reid™ in this document is issued in accordance with a prescribed standard, published performance data or design software. It is the responsibility of the user to obtain its own independent engineering (or other) advice to assess the suitability of the Information for its own requirements. To the extent permitted by law, Reid™ will not be liable to the recipient or any third party for any direct or indirect loss or liability arising out of, or in connection with, the Information. None of the products listed in this document are subject to a warning or ban under the Building Act 2004.