

Retrofitting SwiftLift™ Anchors into Precast units.

Tensile & Shear Lift

Where the anchors are to be loaded in either tension or, shear, such as on the walls of a horizontal pipe or on vertical risers or where 4 anchors are utilised on a horizontal pipe, a recess must be created to engage with the lifting clutch to prevent bending of the anchor during lifting. The anchor then must be installed using **Epcon C6 plus** to ensure the full working load limit of the anchor as published is maintained for the specific concrete compressive strength at the time of lifting.

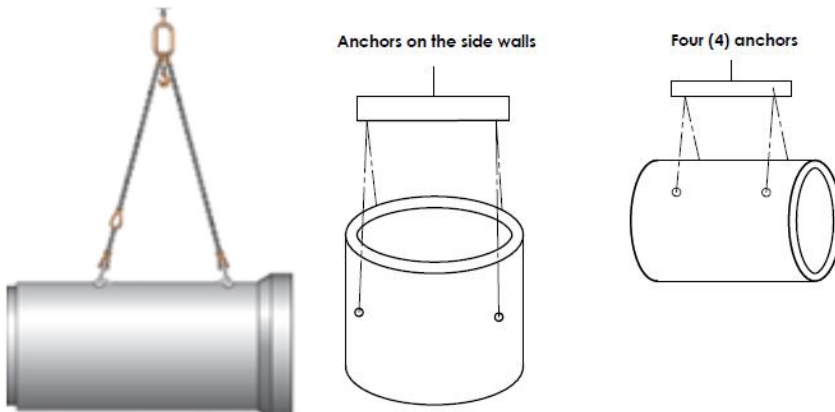

The spherical recess is formed using a special diamond reaming tool from Holer Diamond Tools.



DRP-060-001	DRP-075-001	DRP-100-001
9420050798299	9420050798305	9420050798312
Reamer Ø60mm 1,3 tonne	Reamer Ø75mm 2,5 tonne	Reamer Ø100mm 5,0 tonne

Table 1: Holer Reamer details dimensions



P: +64 (03) 543-9750
F: +64 (03) 544-0110

E: info@holer.co.nz
W: www.holer.co.nz

Table 2: Installation Dimensions

Anchor Size	1.3t x 35mm	1.3t (≥45mm)	2.5t (≥55mm)	5t (≥65mm)
Minimum Wall thickness	45	53	65	75
A ₁ (upper clearance hole dia)	27	27	38	52
A ₂ (lower clearance hole dia)	30	27	38	52
B (through hole dia)	20	20	28	38
C (Recess diameter)	60	60	74	100
D (clearance hole depth)	28	28	32	39
E (min epoxy bond depth)	11 (REF)	19 (REF)	25 (REF)	25 (REF)
F (head depth)	5±3	5±3	7±5mm	10±7mm
G (foot recess depth)	6±1	6±1	8±1	11±1

Installation Instructions

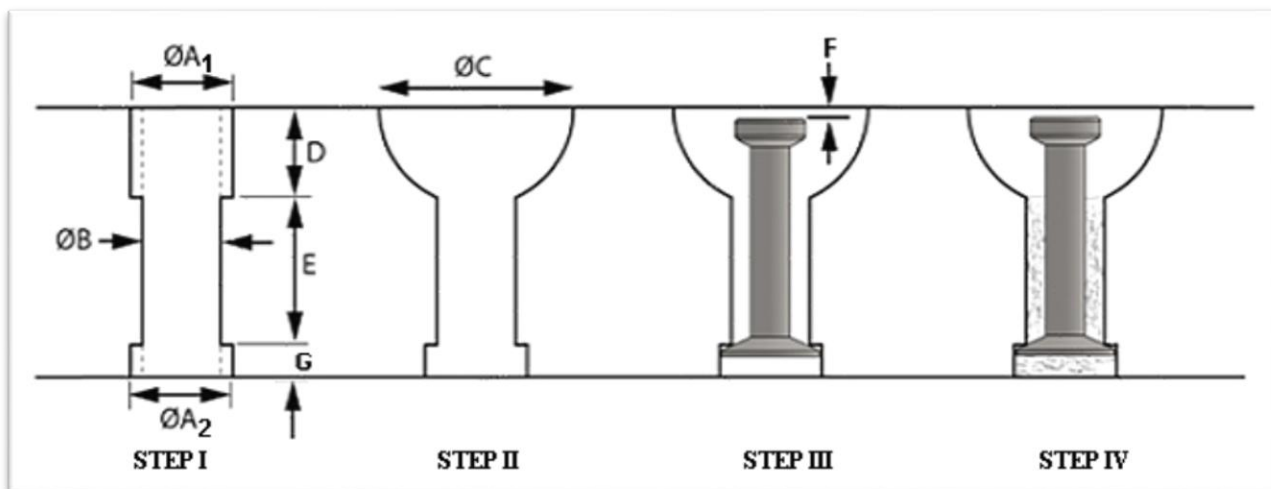

NOTE: WORK MUST BE CARRIED OUT BY A COMPETENT PERSON.

1. Ensure the precast unit is safely chocked before commencing work.
2. Choose a SwiftLift anchor approximately 10-15mm shorter than the total depth of the concrete and with the same nominal capacity as originally specified.
3. Drill the through hole B per Table 2 (as per STEP I above)
4. Drill the clearance holes A_{1&2} per Table 2 to the correct depths from each side per Table 2.

5. Grind The recess using the correct spherical diamond reamer from table 2, **(as per STEP II above)** to the depth and diameter per Table 2.



Note a rubber void former can be used to check the spherical void is the correct depth.

6. Thoroughly clean the hole using a hole cleaning brush and compressed air to remove all dust and debris.
7. Place the SwiftLift anchor in the hole and confirm correct position has been achieved with a clutch **(as per STEP III above)**
8. Fill using Ramset **Epcon C6 plus** Epoxy FOLLOWING THE INSTALLATION INSTRUCTIONS: [Chemset Technical Data Sheet](#) **(as per STEP IV above)**
9. Lift the anchor into final position and remove any excess epoxy on the head and shaft of the anchor and around the recess in the concrete
10. Support the anchor in position until epoxy begins to cure
11. Allow 24 hours before loading the SwiftLift anchor.
12. The anchor must be proof tested in accordance with the Proof Load Test Procedure (below) prior to use.